

# 9091 & 9092 Miniature SIP Relays

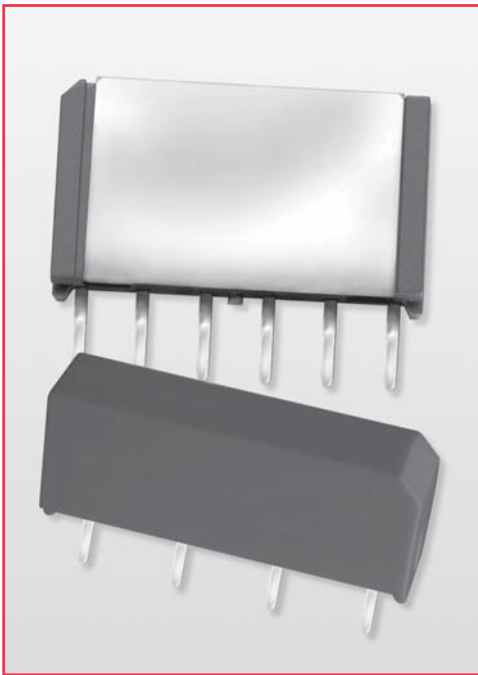

## Miniature Molded SIP Reed Relays

The 9091 is a compact version of the 9001 using 40% less board space (LxW). Because of its increased height, the 9092 model allows for incorporation of 2 form A switches in the same board space. These miniature SIP relays utilize Coto's 10W switch technology, making these SIP relays ideal for use in ATE applications and other high reliability test, measurement and telecommunications applications where high board density and long life are key requirements.

## Series Features

- ◆ 9091 is a 10W SIP relay measuring .600" x .150" x .275"
- ◆ 9092 is a 10W SIP relay measuring .600" x .150" x .350"
- ◆ Magnetic shield – reduces interaction
- ◆ Optional coil suppression diode protects coil drive circuits
- ◆ UL File # E67117 – (9092 UL Pending)
- ◆ High insulation resistance,  $10^{12} \Omega$  minimum
- ◆ High speed switching
- ◆ Molded thermoset body on integral lead frame design
- ◆ High reliability, hermetically sealed contacts for long life

### Model 9091

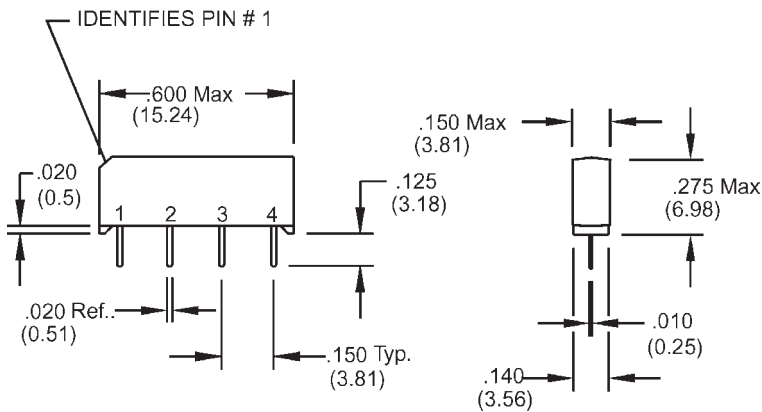

*Dimensions in Inches (Millimeters)*

### Model 9092

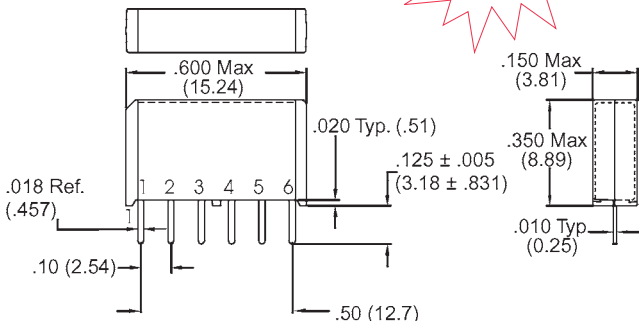

## Ordering Information

Part Number	90XX-XX-1X	General Options <sup>2</sup>
Model Number	9091 9092	0 = No Diode 1 = Diode
Coil Voltage	05 = 5 volts 12 = 12 volts	
Magnetic Shield	(Optional on Model 9091, Std. on 9092)	
	0 = No Shield 1 = Mag Shield (9091 Internal, 9092 External)	

# 9091 & 9092 Miniature SIP Relays



Model Number			9091 <sup>2,4</sup> (10 Watt)		9092 <sup>2,4</sup> (10 Watt)	
Parameters	Test Conditions	Units	1 Form A SIP		2 Form A SIP	
<b>COIL SPECS.</b>						
Nom. Coil Voltage		VDC	5	12	5	12
Max. Coil Voltage		VDC	6.5	15.0	6.5	15.0
Coil Resistance	+/- 10%, 25° C	Ω	500	1000	375	750
Operate Voltage	Must Operate by	VDC - Max.	3.75	9.0	3.75	9.0
Release Voltage	Must Release by	VDC - Min.	0.4	1.0	0.4	1.0
<b>CONTACT RATINGS</b>						
Switching Voltage	Max DC/Peak AC Resist.	Volts	200		200	
Switching Current	Max DC/Peak AC Resist.	Amps	0.5		0.5	
Carry Current	Max DC/Peak AC Resist.	Amps	1.5		1.2	
Contact Rating	Max DC/Peak AC Resist.	Watts	10		10	
Life Expectancy-Typical <sup>1</sup>	Signal Level 1.0V, 10mA	x 10 <sup>6</sup> Ops.	500		500	
Static Contact Resistance (max. init.)	50mV, 10mA	Ω	0.125		0.140	
Dynamic Contact Resistance (max. init.)	0.5V, 50mA at 100 Hz, 1.5 msec	Ω	0.150		0.200	
<b>RELAY SPECIFICATIONS</b>						
Insulation Resistance (minimum)	Between all Isolated Pins at 100V, 25°C, 40% RH	Ω	x 10 <sup>12</sup>		x 10 <sup>12</sup>	
Capacitance - Typical Across Open Contacts		pF	0.1		1.0	
Open Contact to Coil		pF	2.0		1.4	
Dielectric Strength (minimum)	Between Contacts	VDC/peak AC	200		200	
	Contacts to Coil	VDC/peak AC	1500		1500	
Operate Time - including bounce - Typical	At Nominal Coil Voltage, 30 Hz Square Wave	msec.	0.5		0.75	
Release Time - Typical	Zener-Diode Suppression <sup>3</sup>	msec.	0.30		0.5	

Top View:  
Grid = .1"x.1" (2.54mm x 2.54mm)

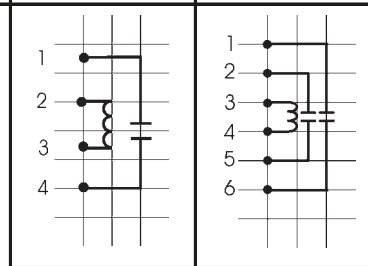

## Notes:

<sup>1</sup>Consult factory for life expectancy at other switching loads. Resistance >0.5Ω defines end of life or failure to open.

<sup>2</sup>Optional diode is connected to pin #2 (+) and pin #3(-) for 9091; pin #3 (+) and pin #4(-) for 9092. Correct coil polarity must be observed.

<sup>3</sup>Consists of 20V Zener-diode and 1N1002 diode in series, connected in parallel with coil.

<sup>4</sup>9091 internal mag shield. 9092 external mag shield.

## Environmental Ratings:

Storage Temp: -35°C to +100°C; Operating Temp: -20°C to +85°C  
Solder Temp: 270°C max; 10 sec. max

The operate and release voltage and the coil resistance are specified at 25°C. These values vary by approximately 0.4%/°C as the ambient temperature varies.

Vibration: 20 G's to 2000 Hz; Shock: 50 G's