

# MDE Semiconductor, Inc.

78-150 Calle Tampico, Unit 210, La Quinta, CA., USA 92253 Tel : 760-564-8656 • Fax : 760-564-2414  
1-800-831-4881 Email: sales@mdesemiconductor.com Web: www.mdesemiconductor.com

## BIDIRECTIONAL THYRISTOR SURGE SUPPRESSOR SERIES

### SURFACE MOUNT SMB AND AXIAL LEAD DO-41

#### FEATURES

- UL94V-0 Flammability Classifier
- ESD Protection >40 kilovolt
- Low Capacitance for T1/E1 Trunk and Line Card Application
- High Surge Current Capability(See Electrical Characteristics)
- Peak Off-State Voltage from 58 to 300 volt
- Meet IEC100-4-4 & -5 Industry Requirement
- Provides Protection in Accordance with FCC Part 68,UL1459,Bellcore 1089,ITU-TK. 20 & K. 2

**DO-204AL (DO-41 Plastic)**

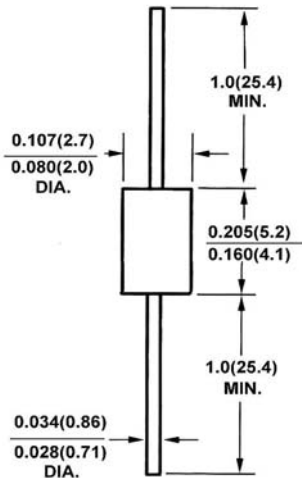

#### MECHANICAL DATA

**Case:** JEDEC DO-41 Molded plastic over passivated junction

**Terminals:** Tin Plated Axial leads, solderable per

MIL-STD-750, Method 2026

**Mounting Position:** Any

**Weight:** 0.012 ounce, 0.3 gram

**DO-214AC (SMA)**

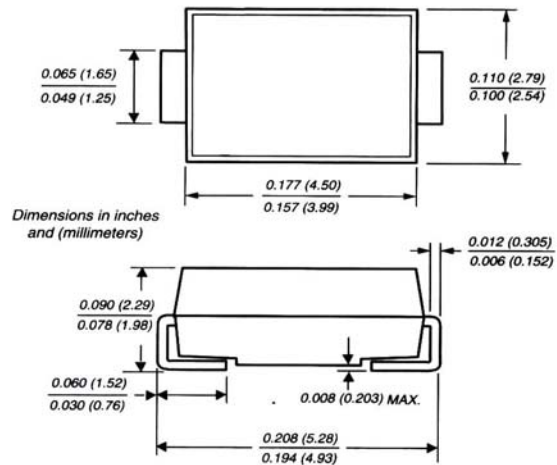

#### MECHANICAL DATA

**Case:** JEDEC DO214AC. Molded plastic over glass passivated junction

**Terminal:** Solder plated, solderable per MIL-STD-750 Method 2026

**Standard Packaging:** 12mm tape (EIA STD RS-481)

**Weight:** 0.002 ounce, 0.061 gram

MDE PART NUMBER	MARKING CODE FOR AXIAL DO-41 PACKAGE	MARKING CODE FOR SMA PACKAGE	REPETITIVE PEAK OFF-STAGE VOLTAGE VDRM VOLTS	SWITCHING VOLTAGE @100V/us Vs VOLTS	MINIMUM HOLDING CURRENT IH mA	SWITCHING CURRENT Is mA	SURGE RATINGS IPP 10x1000 μS Amps	ON-STAGE CURRENT IT A	TYPICAL CAPACITANCE @50V,1MHz pF
P0640SAA	P0640SAAL	G1	58	77	150	800	35	1	60
P0720SAA	P0720SAAL	G2	65	88	150	800	35	1	60
P0800SAA	P0800SAAL	G3	75	98	150	800	35	1	60
P1100SAA	P1100SAAL	G4	90	130	150	800	35	1	60
P1300SAA	P1300SAAL	G5	120	160	150	800	35	1	40
P1500SAA	P1500SAAL	G6	140	180	150	800	35	1	40
P1800SAA	P1800SAAL	G7	160	220	150	800	35	1	40
P2300SAA	P2300SAAL	G8	190	260	150	800	35	1	30
P2600SAA	P2600SAAL	G9	220	300	150	800	35	1	30
P3100SAA	P3100SAAL	GA	275	350	150	800	35	1	30
P3500SAA	P3500SAAL	GB	300	400	150	800	35	1	30
P4000SAA	P4000SAAL	FZ	360	450	150	800	35	1	30

Maximum Off-State Current @VDRM : 5μA

Maximum On-State Voltage @I<sub>T</sub> : 5volts

For AXIAL devices,use suffix L (e.g. P3100AL) electrical charactics apply in both AXIAL and Surface Mounted Devices.

# MDE Semiconductor, Inc.

78-150 Calle Tampico, Unit 210, La Quinta, CA., USA 92253 Tel : 760-564-8656 • Fax : 760-564-2414  
 1-800-831-4881 Email: sales@mdesemiconductor.com Web: www.mdesemiconductor.com

## BIDIRECTIONAL THYRISTOR SURGE SUPPRESSOR SERIES RATINGS AND CHARACTERISTIC CURVES

